

ANTICO

non metallic pumps



MKNS Series - Lined Magnetic Drive Pumps

ANTICO

MKNS SERIES

Chemical pumps for corrosive, toxic or bromine-containing liquids are subject to strict standards when it comes to safety, leaks to the atmosphere and service life. These high requirements are the reasons for the trend towards seal-less in particularly, magnetic drive pumps.

MKNS Lined Magnetic Drive Pumps are designed as per ISO 2858 standard with PFA-P linings. PFA-P linings give improved corrosion resistance as compared to high alloy, expensive metals magnetic drive pumps.

PFA-P stands for Perfluoroalkoxy Permeation Grade. PFA-P is processed in transfer moulding operation and as a result the lining wall thicknesses can be accurately defined and reproduced. Thanks to its dense molecular structure, PFA-P has generally much lower permeation rates than PTFE with the same wall thicknesses; retaining identical chemical and thermal resistance properties. PFA-P is justifiably the material of first choice in applications with media which have a tendency to permeate; such as chlorine, bromine or fluorine compounds.

In the event of the chemical penetrating the lining, it can cause corrosion on the pressure-bearing metal body and perhaps even failure of the unit. MKNS Lined Magnetic Drive Pumps have PFA-P lining wall thickness of 6-9 mm producing substantially longer service lives.

MKNS Lined Magnetic Drive Pumps are also available with regular PFA Lining. Other Lining options like PVDF, available on request against specific applications.



Magnetic Drive Pump Overview

In a standard centrifugal pump, the power is delivered to the pump end either through a direct connection between the rotating element and the motor shaft or through a coupling between the pump end shaft and the motor shaft.

In these cases, the pumping chamber needs to be sealed from the outside. Traditionally, packing or some other sort of mechanical seal accomplishes this.

The principle of a magnetic drive pump is that the rotation from the motor shaft is transferred to the pump end via a magnetic coupling which eliminates the need for the shaft seal or packing.

A drive magnet is mounted to the motor shaft, which transfers the motor torque through a sealed housing to an internal driven magnet. The driven magnet is coupled directly to the impeller. This configuration is categorized as seal-less.

The following will give an idea of approximate leakage rate for various Sealing arrangements:

| | |
|------------------------|---------------|
| Gland Packing | > 1000 ppm |
| Single Mechanical Seal | 10 - 1000 ppm |
| Double Mechanical Seal | < 10 ppm |
| Sealless | 0 ppm |

Lined Magnetic Drive Pump Offers Several Advantages:

1. Improved Corrosion Resistance: Outer Body in Ductile Iron give rigidity to handle pump internal pressure and nozzle loads. PFA lining provides improved corrosion resistance.
2. Lower Initial Costs: A significant factor while considering metallurgies like Hastalloy or Titanium.
3. Zero Eddy Current Losses: Power losses due to electrical currents produced by the rotating lines of magnetic flux cutting through a stationary conductor. These power losses translate into heat which is transferred to the pumping media.

In case of metal shells, these losses could range from 10-20% of magnetic drive rating.

For Non-Conductive shells, this is not observed since no eddy currents are generated.

4. Close Coupled Design: Outer magnet directly mounted on Motor shaft which does not require a separate pump bearing frame. This eliminates the need for coupling alignment allowing much shorter overall length.

Design Features

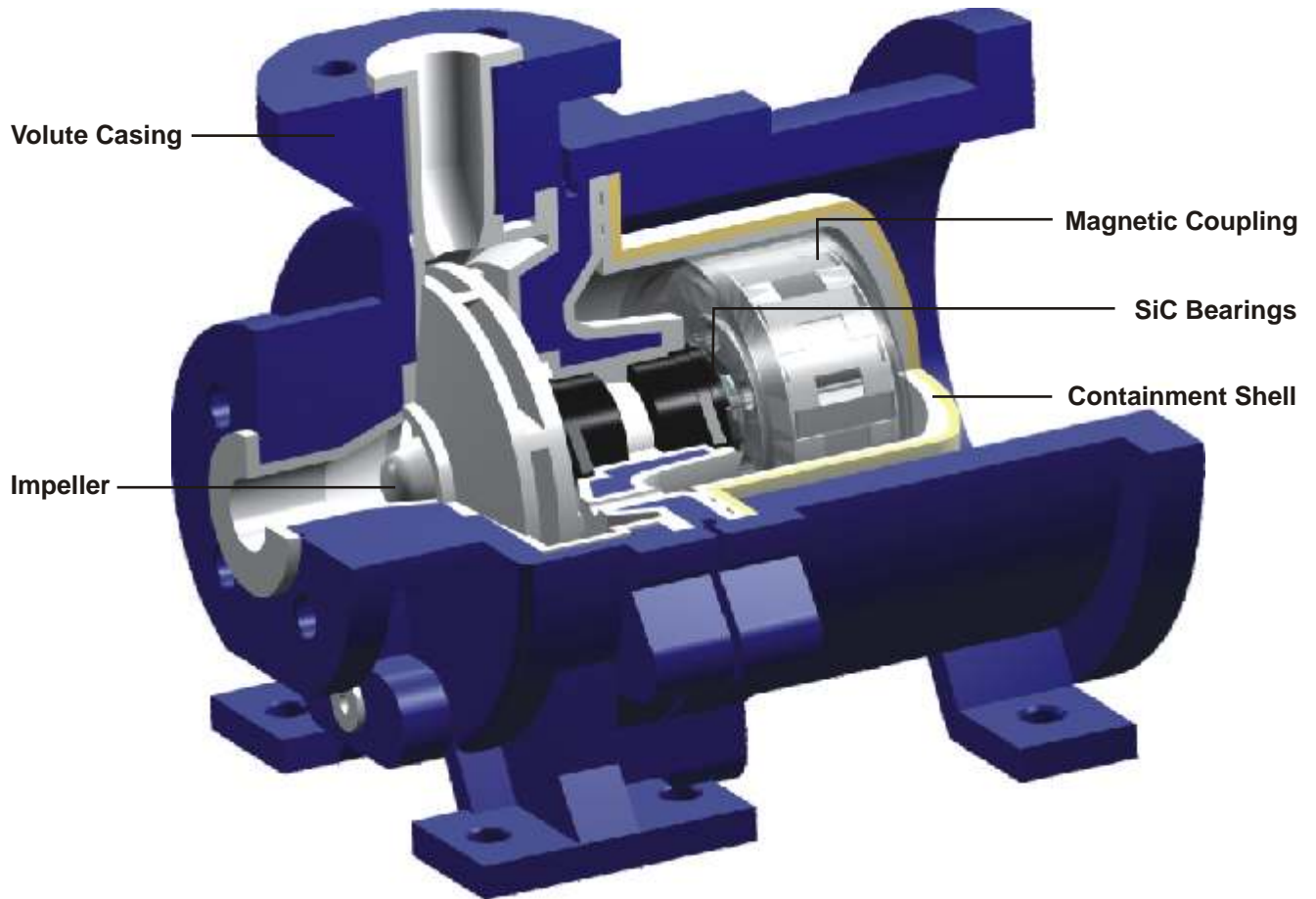

1 Volute Casing: Top centerline discharge, lined with PFA-P. Minimum lining thickness of 6 mm, lining locked by multiple locking grooves. Outer body ductile iron, other materials like stainless steel available on request.



2 Impeller: All impellers precision moulded in PFA-P, light in weight, closed construction. Closed impellers result in lower power requirements and higher efficiencies.



3 Bearings: Impeller, Shaft and Magnetic Rotor are mounted on Sintered Silicon Carbide Bearings lubricated by process media via internal grooves. Bearings withstand brief dry running and lack of lubrication.



4 Shaft: Solid stainless steel with PFA-P lining.



5 Magnetic Coupling: Power transmitted to the pump by high quality samarium cobalt magnet. Product side wetted rotor is PFA-P lined.



6 Isolation Shell: Made from PVDF / carbon fibre reinforced plastic (CFRP) with PFA-P inner shell is free from Eddy Currents thus prevents additional heating of the Pumping Media.



Recommended Accessories

Lined Basket Strainers:



MKNS Magnetic Drive Pumps have closed impellers and close tolerances between SiC bearings. Any foreign particulate matter can clog the impeller and bearings thus jamming the pump resulting in severe damages. Lined Basket Strainers are an ideal accessory to prevent this type of damage.

KNS Lined Basket Strainer offer following advantages:

- PFA/FEP Lining offers highest corrosion resistance minimum lining thickness of 3mm, lining locked by multiple locking grooves.
- Outer body graded cast iron as per ASTM Standard, other materials like cast steel / stainless steel available on request.
- Strainer Basket made of PTFE / FEP / PVDF. Standard Mesh Size 0.25 mm other sizes available on request.
- Available in sizes from 25 NB to 100 NB.

Pump Protection Relays:



Pump Protection Relays are Motor Protection Relays designed for trouble free pump operation. They protect pump against dry running, jamming of motor, closed suction valve or no-flow, over current etc.



Anticorrosive Equipment Pvt Ltd

15, Hind Service Industries, 2nd Floor,
Off V. S. Road, Shivaji Park, Mumbai - 400 028, India
Phone : +91 22 2446 6496, 2446 8340, 2445 3501
Fax : +91 22 2444 9271
info@anticopumps.co.in www.anticopumps.co.in

